

HARDI® PUMP 1303



General specifications

- Three diaphragm positive displacement pump.
- Base plate incorporated in crankcase.
- Self-priming.
- Can be run dry.
- Can rotate clockwise or anticlockwise.
- Three grease points for lubrication.
- Dry sump to simplify maintenance.
- No special tools needed for maintenance.
- Polyurethane diaphragms and seals.
- Stainless steel diaphragm discs and bolts.
- Cast iron crankcase and covers.
- 1¼" suction port, 1" pressure port.
- Recommended to use HARDI® suction and pressure dampers.

1303/6.0 (Ref. no. 821634)

- Tapered shaft for tractor use with HARDI® transmission shaft.
- Normal operating revolutions, 1000 r/min.
- Maximum pressure, 15 bar / 220 PSI.
- Maximum vacuum, 0.26 bar / 3.8 PSI.
- Weight, 37.7 kg / 83 lb.

1303/9.0 (Ref. no. 821635)

- Tapered shaft for tractor use with HARDI® transmission shaft.
- Normal operating revolutions, 540 r/min.
- Maximum pressure, 15 bar / 220 PSI.
- Maximum vacuum, 0.57 bar / 8.4 PSI.
- Weight, 37.7 kg / 83 lb.



1303 for reliable operation

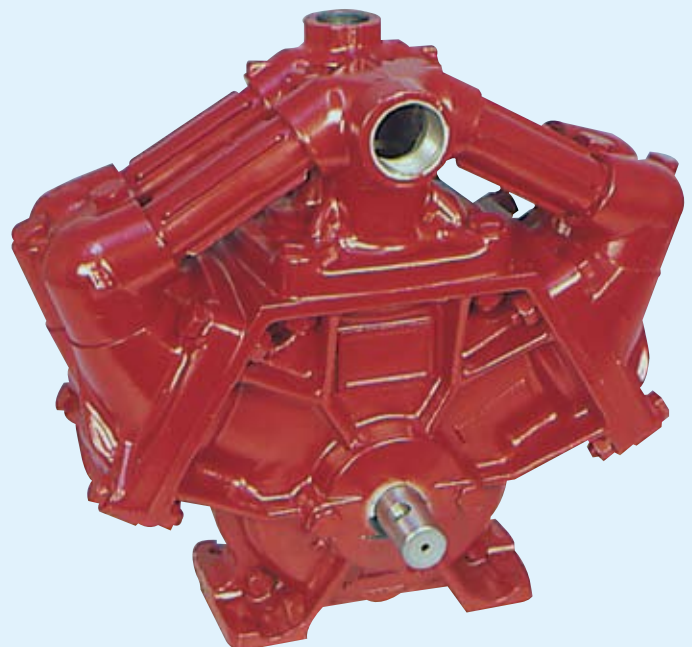

1303 pump

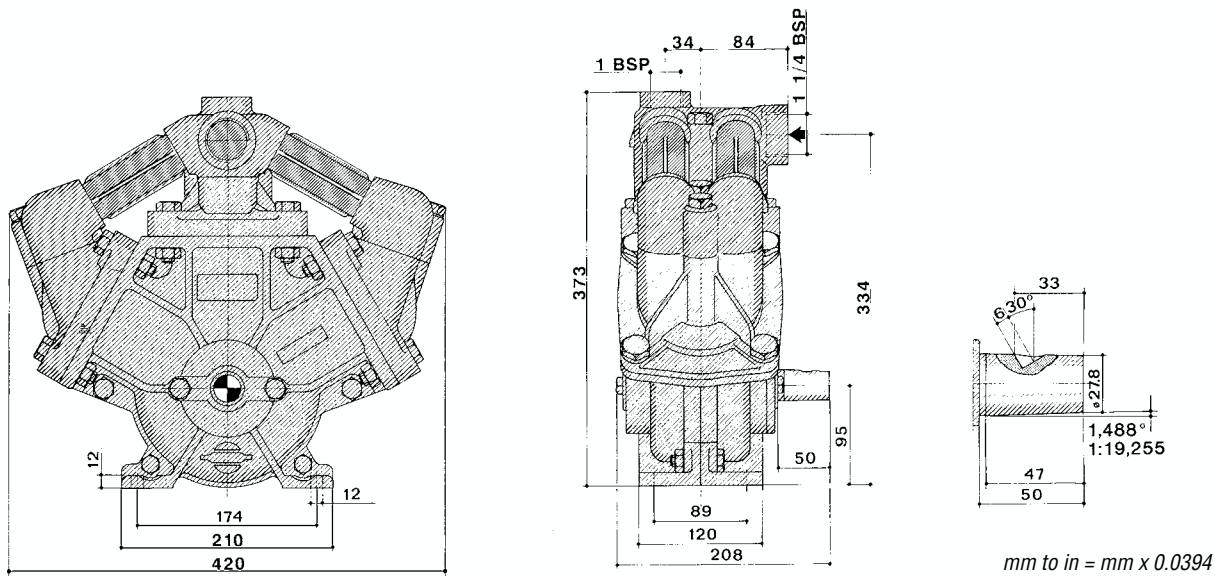

	r/min	300		400		500		540		600		700		800		900		1000		1100		1200			
		bar	l/min	kW	l/min	kW	l/min	kW			l/min	kW	l/min	kW	l/min	kW	l/min	kW	l/min	kW	l/min	kW	l/min	kW	
1303/6.0	0	41	0.9	54	1.2	70	1.5			82	1.8	94	2.1	106	2.4	122	2.6	136	3.0	151	3.3	165	3.6		
	2	38	0.9	51	1.2	64	1.5			75	1.8	86	2.1	98	2.4	109	2.7	122	3.0	134	3.3	146	3.6		
	4	37	1.0	49	1.3	62	1.6			73	1.9	83	2.2	94	2.4	104	2.7	116	3.1	130	3.3	138	3.6		
	6	36	1.0	48	1.3	60	1.6			70	2.0	81	2.3	91	2.7	101	3.0	113	3.3	124	3.6	133	4.1		
	10	34	1.1	46	1.4	57	1.8			67	2.2	77	2.6	87	3.0	97	3.3	108	3.7	117	4.1	128	4.6		
	15	33	1.4	44	1.7	54	2.2			64	2.7	73	3.1	82	3.6	92	4.1	103	4.5	113	4.9	123	5.3		
		PSI	gpm	Hp	gpm	Hp	gpm	Hp			gpm	Hp	gpm	Hp	gpm	Hp	gpm	Hp	gpm	Hp	gpm	Hp	gpm	Hp	
		0	10.8	1.2	14.3	1.6	18.5	2.0			21.6	2.4	24.8	2.8	28.0	3.2	32.2	3.5	35.9	4.0	39.9	4.4	43.6	4.8	
		29	10.0	1.2	13.5	1.6	16.9	2.0			19.8	2.4	22.7	2.8	25.9	3.2	28.8	3.6	32.2	4.0	35.4	4.4	38.5	4.8	
		58	9.8	1.3	12.9	1.7	16.4	2.1			19.3	2.5	21.9	3.0	24.8	3.2	27.5	3.6	30.6	4.2	34.3	4.4	36.4	4.8	
	88	9.5	1.3	12.7	1.7	15.8	2.1			18.5	2.7	21.4	3.1	24.0	3.6	26.7	4.0	29.8	4.4	32.7	4.8	35.1	5.5		
	147	9.0	1.5	12.1	1.9	15.0	2.4			17.7	3.0	20.3	3.5	23.0	4.0	25.6	4.4	28.5	5.0	30.9	5.5	33.8	6.2		
	220	8.7	1.9	11.6	2.3	14.3	3.0			16.9	3.6	19.3	4.2	21.6	4.8	24.3	5.5	27.2	6.0	29.8	6.6	32.5	7.1		
1303/9.0		bar	l/min	kW	l/min	kW	l/min	kW	l/min	kW	l/min	kW	l/min	kW	l/min	kW	l/min	kW	l/min	kW	l/min	kW	l/min	kW	
		0	63	0.9	84	1.2	103	1.5	114	1.6	125	1.8	144	2.1											
		2	61	0.9	81	1.2	100	1.5	107	1.7	120	1.9	137	2.1											
		4	59	0.9	79	1.3	97	1.6	104	1.7	117	1.9	133	2.2											
		6	58	1.0	78	1.3	96	1.7	102	1.8	115	2.1	131	2.4											
		10	56	1.3	76	1.8	94	2.3	100	2.5	111	2.7	126	3.2											
		15	55	1.8	74	2.4	92	3.0	98	3.3	108	3.8	123	4.4											
			PSI	gpm	Hp	gpm	Hp	gpm	Hp	gpm	Hp	gpm	Hp	gpm	Hp										
		0	16.6	1.2	22.2	1.6	27.2	2.0	30.1	2.1	33.0	2.4	38.0	2.8											
		29	16.1	1.2	21.4	1.6	26.4	2.0	28.2	2.3	31.7	2.5	36.2	2.8											
	58	15.6	1.2	20.9	1.7	25.6	2.1	27.5	2.3	30.9	2.5	35.1	3.0												
	88	15.3	1.3	20.6	1.7	25.3	2.3	26.9	2.4	30.4	2.8	34.6	3.2												
	147	14.8	1.7	20.1	2.4	24.8	3.1	26.4	3.4	29.3	3.6	33.3	4.3												
	220	14.5	2.4	19.5	3.2	24.3	4.0	25.9	4.4	28.5	5.1	32.5	5.9												

Model/stroke Pump model and pump stroke in millimetre.
r/min Maximum revolutions per minute is indicated by the highest figure.
Bar / PSI Maximum pressure is indicated by the highest figure.
kW / Hp Power consumption in kilowatt and horsepower.
l/min / gpm Capacity in litres and US gallons per minute at zero suction lift.

HARDI® NORTH AMERICA INC.
 1500 WEST 76th STREET 8550 W. ROOSEVELT AVENUE 290 SOVEREIGN ROAD
 DAVENPORT, IA. 52806 VISALIA, CA 93291 LONDON, ON N6M 1B3
 Phone: (563) 386-1730 Phone: (559) 651-4016 Phone: (519) 659-2771
 Fax: (563) 386-1710 Fax: (559) 651-4160 Fax: (519) 659-2821
<http://www.hardi-us.com>

HIA-MARKETING US-890645-05-2003