

HARDI PUMP 363



General specifications

- Six diaphragm positive displacement radial pump with base plate.
- Self-priming.
- Can be run dry.
- Can rotate clockwise or anticlockwise.
- One grease point for lubrication.
- Dry sump to simplify maintenance.
- No special tools needed for maintenance.
- Polyurethane diaphragms and seals.
- Cast iron crankcase and covers.
- Stainless steel bolts and plates for diaphragms.
- 1½" suction port, 1" pressure port.
- Hydraulic drive kit available.

363/5.5 (Ref. no. 821651)

- 21-splined 1³/₈" shaft, for tractor use.
- Normal operating revolutions, 1000 r/min.
- Maximum pressure, 15 bar / 220 PSI.
- Maximum vacuum, 0.48 bar / 7.1 PSI.
- Weight, 52.2 kg / 115 lb.
- Offset Ports

363/7.0 (Ref. no. 821643)

- 6-splined 1³/₈" shaft, for tractor use.
- Normal operating revolutions, 540 r/min.
- Maximum pressure, 20 bar / 294 PSI.
- Maximum vacuum, 0.54 bar / 7.9 PSI.
- Weight, 52.6 kg / 116 lb.
- Offset Ports

363/10.0 (Ref. no. 821579)

- 6-splined 1³/₈" shaft, for tractor use.
- Normal operating revolutions, 540 r/min.
- Maximum pressure, 15 bar / 220 PSI.
- Maximum vacuum, 0.64 bar / 9.4 PSI.
- Weight, 52.5 kg / 116 lb.

363/10.0 (Ref. no. 821580)

- 6-splined 1³/₈" through shaft, for tractor use.
- Normal operating revolutions, 540 r/min.
- Maximum pressure, 15 bar / 220 PSI.
- Maximum vacuum, 0.64 bar / 9.4 PSI.
- Weight, 52.9 kg / 117 lb.



363 with hydraulic drive



363 with splined shaft

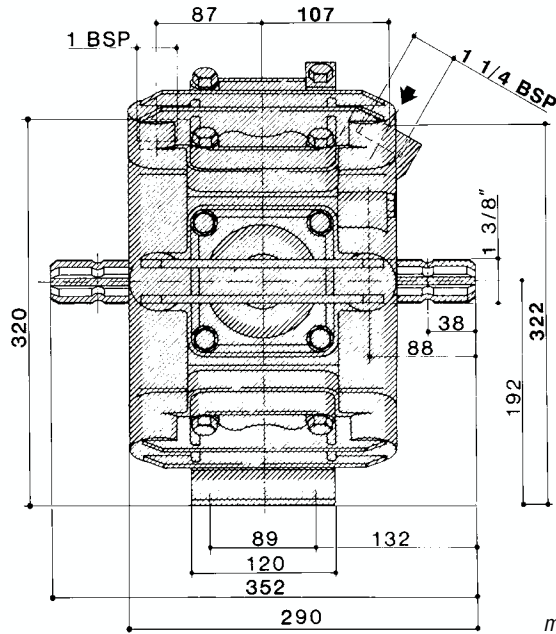
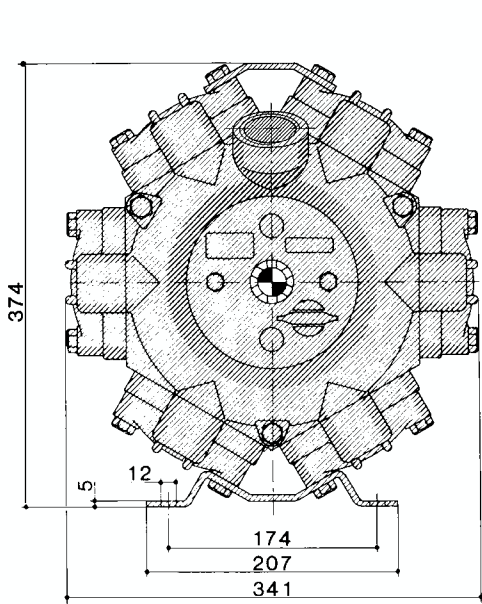

mm to in = mm x 0.0394

	300		400		500		540		600		700		800		900		1000		1100		1200		
	bar	l/min	kW	l/min	kW	l/min	kW		l/min	kW	l/min	kW	l/min	kW	l/min	kW	l/min	kW	l/min	kW	l/min	kW	
363/5.5	0	61	1.0	82	1.3	103	1.5		123	1.9	144	2.2	164	2.4	186	2.8	201	3.1	213	3.4	225	3.7	
	2	59	1.0	79	1.3	100	1.5		119	1.9	140	2.2	160	2.5	179	2.9	191	3.2	200	3.5	208	3.8	
	4	58	1.0	78	1.4	98	1.7		117	2.1	138	2.4	155	2.8	176	3.3	188	3.6	199	3.9	204	4.3	
	6	57	1.1	76	1.4	96	2.0		115	2.4	134	2.9	153	3.5	173	3.9	186	4.3	196	4.7	202	5.1	
	10	55	1.6	74	2.1	94	2.7		112	3.2	130	3.8	148	4.4	168	5.2	180	5.6	190	6.1	200	6.6	
	15	53	2.0	72	2.6	89	3.3		108	4.1	126	4.9	144	5.7	163	6.6	174	7.1	185	7.9	196	8.4	
		PSI	gpm	Hp	gpm	Hp	gpm	Hp		gpm	Hp	gpm	Hp	gpm	Hp	gpm	Hp	gpm	Hp	gpm	Hp	gpm	Hp
		0	16.1	1.3	21.6	1.7	27.2	2.0		32.5	2.5	38.0	3.0	43.3	3.2	49.1	3.8	53.1	4.2	56.2	4.6	59.4	5.0
		29	15.6	1.3	20.9	1.7	26.4	2.0		31.4	2.6	37.0	3.0	42.2	3.4	47.3	3.9	50.4	4.3	52.8	4.7	54.9	5.1
		58	15.3	1.3	20.6	1.9	25.9	2.3		30.9	2.8	36.4	3.2	40.9	3.8	46.5	4.4	49.6	4.8	52.5	5.2	53.9	5.8
	88	15.0	1.5	20.1	1.9	25.3	2.7		30.4	3.2	35.4	3.9	40.4	4.7	45.7	5.2	49.1	5.8	51.7	6.3	53.3	6.8	
	147	14.5	2.1	19.5	2.8	24.8	3.6		29.6	4.3	34.3	5.1	39.1	5.9	44.4	7.0	47.5	7.5	50.2	8.2	52.8	8.9	
	220	14.0	2.7	19.0	3.5	23.5	4.4		28.5	5.5	33.3	6.6	38.0	7.6	43.0	8.9	45.9	9.5	48.8	10.6	51.7	11.3	
363/7.0	0	78	0.9	104	1.2	131	1.6	140	1.6	156	1.9	183	2.2										
	2	76	1.0	102	1.3	128	1.7	136	1.8	152	2.0	177	2.3										
	4	74	1.3	98	1.5	125	1.9	133	2.1	147	2.4	170	2.8										
	6	73	1.4	97	1.8	121	2.3	130	2.5	144	2.9	167	3.5										
	10	71	1.8	95	2.4	117	3.1	127	3.4	141	3.8	164	4.6										
	15	70	2.4	92	3.2	115	3.9	124	4.4	137	5.0	161	5.9										
	20	68	2.9	90	3.9	113	4.8	122	5.4	135	5.9	158	7.0										
		PSI	gpm	Hp	gpm	Hp	gpm	Hp	gpm	Hp	gpm	Hp	gpm	Hp									
		0	20.6	1.2	27.5	1.6	34.6	2.1	37.0	2.1	41.2	2.5	48.3	3.0									
		29	20.1	1.3	26.9	1.7	33.8	2.3	35.9	2.4	40.1	2.7	46.7	3.1									
	58	19.5	1.7	25.9	2.0	33.0	2.5	35.1	2.8	38.8	3.2	44.9	3.8										
	88	19.3	1.9	25.6	2.4	31.9	3.1	34.3	3.4	38.0	3.9	44.1	4.7										
	147	18.7	2.4	25.1	3.2	30.9	4.2	33.5	4.6	37.2	5.1	43.3	6.2										
	220	18.5	3.2	24.3	4.3	30.4	5.2	32.7	5.9	36.2	6.7	42.5	7.9										
	294	18.0	3.9	23.8	5.2	29.8	6.4	32.2	7.2	35.6	7.9	41.7	9.4										
363/10.0	0	107	0.9	141	1.4	178	1.7	194	1.8	211	2.0	229	2.4										
	2	105	1.3	140	1.5	175	2.1	189	2.3	207	2.6	225	3.2										
	4	103	1.5	139	2.1	172	2.5	186	2.9	205	3.3	224	3.9										
	6	102	1.8	138	2.5	169	3.2	184	3.5	203	3.9	223	4.6										
	10	100	2.5	135	3.4	166	4.4	182	4.7	200	5.2	220	6.0										
	15	98	3.3	132	4.5	164	5.6	178	6.2	197	6.6	217	7.6										
		PSI	gpm	Hp	gpm	Hp	gpm	Hp	gpm	Hp	gpm	Hp	gpm	Hp									
		0	28.2	1.2	37.2	1.9	47.0	2.2	51.2	2.4	55.7	2.7	60.5	3.2									
		29	27.7	1.7	37.0	2.1	46.2	2.8	49.9	3.1	54.6	3.5	59.4	4.3									
		58	27.2	2.0	36.7	2.7	45.4	3.4	49.1	3.9	54.1	4.4	59.1	5.2									
	88	26.9	2.5	36.4	3.4	44.6	4.2	48.6	4.6	53.6	5.3	58.9	6.2										
	147	26.4	3.4	35.6	4.5	43.8	6.0	48.0	6.4	52.8	7.0	58.1	8.1										
	220	25.9	4.5	34.8	6.0	43.3	7.5	47.0	8.4	52.0	8.8	57.3	10.2										

Model/stroke
r/min
Bar / PSI
kW / Hp
l/min / gpm

Pump model and pump stroke in millimetre.
Maximum revolutions per minute is indicated by the highest figure.
Maximum pressure is indicated by the highest figure.
Power consumption in kilowatt and horsepower.
Capacity in litres and US gallons per minute at zero suction lift.

HARDI® NORTH AMERICA INC.

1500 WEST 76th STREET 8550 W. ROOSEVELT AVENUE 290 SOVEREIGN ROAD
DAVENPORT, IA 52806 VISALIA, CA 93291 LONDON, ON N6M 1B3
Phone: (563) 386-1730 Phone: (559) 651-4016 Phone: (519) 659-2771
Fax: (563) 386-1710 Fax: (559) 651-4160 Fax: (519) 659-2821
<http://www.hardi-us.com>