

# HARDI PUMP 463 D



## General specifications

- Two high capacity, six diaphragm radial pumps.
- Coupled together on base plate.
- Positive displacement.
- Self-priming.
- Can be run dry.
- Can rotate clockwise or anticlockwise.
- Two grease points for lubrication.
- Dry sump to simplify maintenance.
- No special tools needed for maintenance.
- Polyurethane diaphragms and seals.
- Cast iron crankcase and covers.
- Stainless steel bolts and plates for diaphragms.
- 2<sup>1</sup>/<sub>2</sub>" suction port, 1<sup>1</sup>/<sub>2</sub>" pressure port.
- Hydraulic drive kit available.

## 463/12.0 Double (Ref. no. 848078)

- 6-splined 1<sup>3</sup>/<sub>8</sub>" shaft.
- Normal operating revolutions, 540 r/min.
- Liquid temperature, max. 40° / 104°F.
- Maximum pressure, 15 bar / 220 PSI.
- Maximum vacuum, 0.30 bar / 4.4 PSI.
- Weight, 155 kg / 342 lb.



463 D for high capacity

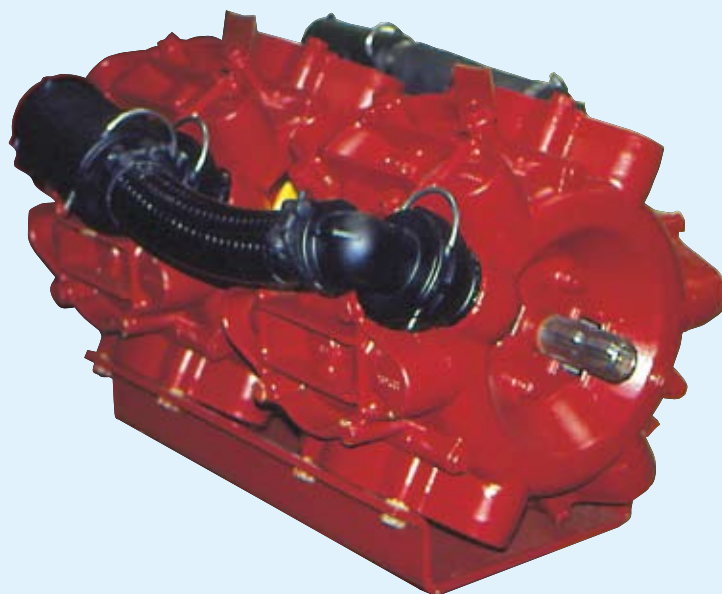

463 with splined shaft

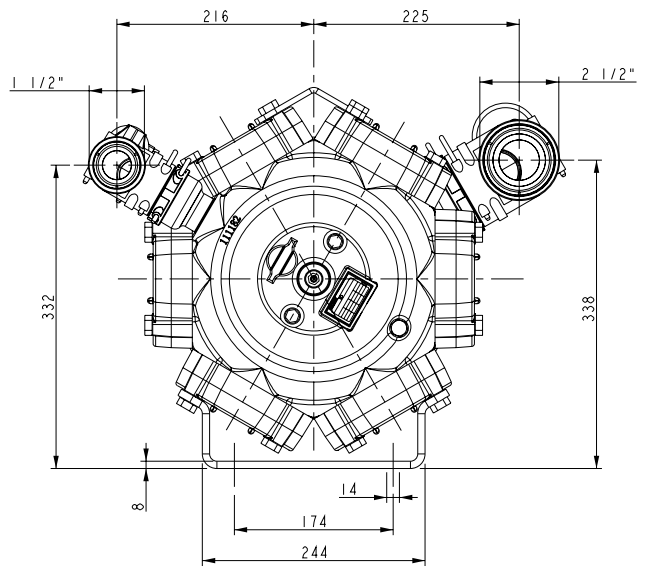
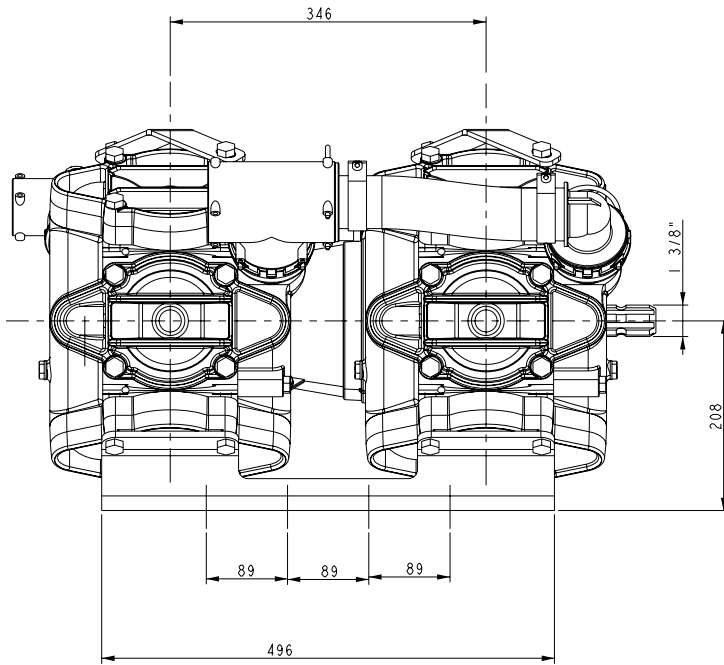

mm to in = mm x 0.0394

463/12.0 Double	r/min		300		400		500		540		600		700		
	bar	l/min	kW	l/min	kW	l/min	kW	l/min	kW	l/min	kW	l/min	kW	l/min	kW
	0	363	2.0	479	2.8	592	3.8	620	4.4	670	5.3	745	7.2		
	2	355	2.8	473	4.0	583	5.4	600	6.2	645	7.2	715	9.5		
	4	350	3.6	465	5.4	576	7.9	592	8.4	635	10.0	700	11.8		
	6	344	5.2	460	7.0	567	9.2	581	10.2	625	12.0	689	15.2		
	10	335	7.0	445	10.0	558	12.8	570	14.2	616	15.9	678	18.8		
	15	325	8.1	435	11.5	543	13.6	558	14.8	605	16.6	667	20.5		
	PSI	gpm	Hp	gpm	Hp	gpm	Hp	gpm	Hp	gpm	Hp	gpm	Hp	gpm	Hp
	0	96.0	2.7	126.4	3.6	156.3	5.1	163.7	5.9	176.9	7.1	196.7	9.7		
	29	94.0	3.8	124.8	5.4	153.9	7.2	158.4	8.3	170.3	9.7	188.7	12.7		
	58	92.4	4.8	122.7	7.2	152.0	10.6	156.3	11.5	167.6	13.4	184.8	15.8		
	88	90.8	7.0	121.4	9.4	149.7	12.3	153.4	13.7	165.0	16.1	181.9	20.4		
147	88.4	9.4	117.5	13.3	147.3	17.2	150.5	19.0	162.6	21.3	179.0	25.2			
220	85.8	10.9	114.8	15.4	143.4	18.2	147.3	19.9	159.7	22.3	176.0	27.5			

**Model/stroke** Pump model and pump stroke in millimetre.  
**r/min** Maximum revolutions per minute is indicated by the highest figure.  
**Bar / PSI** Maximum pressure is indicated by the highest figure.  
**kW / Hp** Power consumption in kilowatt and horsepower.  
**l/min / gpm** Capacity in litres and US gallons per minute at zero suction lift.

**HARDI® INC.**

1500 WEST 76th STREET 290 SOVEREIGN ROAD 5646 WEST BARSTOW, SUITE 101  
 DAVENPORT, IA. 52806 LONDON, ON N6M 1B3 FRESNO, CA 93722  
 TEL: (319) 386-1730 TEL: (519) 659-2771 TEL: (559) 271-3106  
 FAX: (319) 386-1710 FAX: (519) 659-2821 FAX: (559) 271-3107

890615-09.2000